

# SPC1 Series

## ■ Features

### ● Various and simple input specification

- 4–20mADC, 1–5VDC
- External VR(1kΩ)
- ON/OFF (External contact)

### ● Various function

- Out ADJ function
- Soft Start function(Except for ON/OFF control type)
- Out display function
- 50/60Hz automatic converting function

### ● Various control type by mode SW

- Phase control type
- Cycle control type(Zero Cross)
- ON/OFF control type(Zero Cross)



**⚠ Please read "Caution for your safety" in operation manual before using.**

## ■ Ordering information

<b>SPC</b>	<b>1</b>	–	<b>35</b>	
		Rated current	35	35A
			50	50A
			1	Single phase
		*	3	3 phases
		SPC	Series name (Solid state Power Controller)	

\*3 phases is upcoming.

## ■ Specifications

Model		SPC1-35	SPC1-50
Power supply		220VAC 50/60Hz	
Allowable voltage range		90 ~ 110% of rated voltage	
Maximum rated current		35A	50A
Control power		220VAC	
Control range		0 ~ 100% (Except for triac voltage drop)	
Applied load		Resistance load (Min. load : Over 5% of rated current)	
Cooling method		Internal heat sink	
Control circuit		Micom control type	
Control input		●1–5VDC                      ●4–20mADC (250Ω)                      ●ON/OFF (External relay contact) ●External VR(1kΩ)        ●Output limit input (Inner VR)	
Control mode		Phase control Cycle control (Zero Cross) – Period 0.5sec, 2.0sec, 10sec selectable ON/OFF control (Zero Cross)	
Starting type		Soft Start (0~50 sec variable) – Only for phase control and cycle control	
Display		Output indication (LED)	
Insulation resistance		100MΩ (at 500VDC)	
Dielectric strength		2000VAC for 1minute	
Noise strength		±2kV the square wave noise (pulse width:1μs) by the noise simulator	
Vibration	Mechanical	0.75mm amplitude at frequency of 10 ~ 55Hz in each of X, Y, Z directions for 1hour	
	Malfunction	0.5mm amplitude at frequency of 10 ~ 55Hz in each of X, Y, Z directions for 10min.	
Shock	Mechanical	300m/s <sup>2</sup> (30G) in X, Y, Z directions for 3 times	
	Malfunction	100m/s <sup>2</sup> (10G) in X, Y, Z directions for 3 times	
Ambient temperature		0 ~ +50°C (at non-freezing status)	
Storage temperature		–25 ~ +65°C (at non-freezing status)	
Ambient humidity		35 ~ 85%RH	
Weight		Approx. 1kg	

# Power Controller

## Dimensions

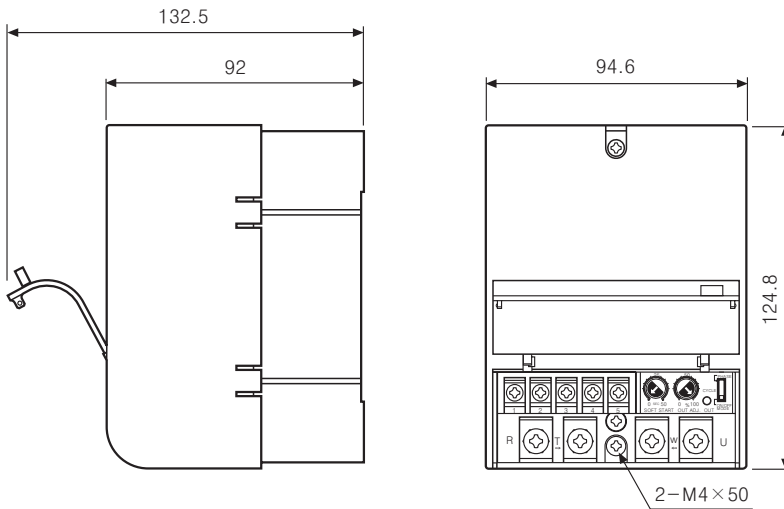

### Panel lay-out

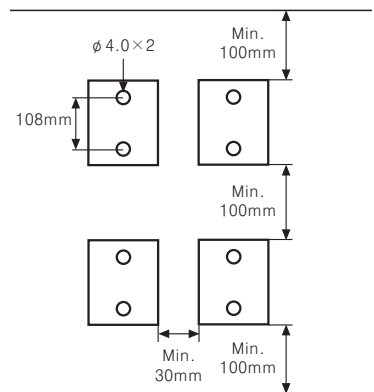

※ It should have enough space between units for proper cooling.

## Connections

### 1. External connection

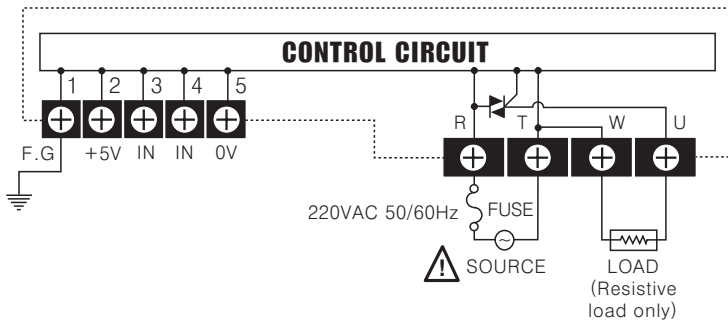

### 2. Connection of control input terminals

#### 1) 4-20mADC control input

It controls 0 to 100% when you apply 4 to 20mADC on ④, ⑤ terminals when power is applied.

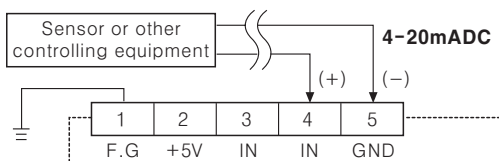

#### 2) 1-5VDC control input

It controls 0 to 100% when you apply 1 to 5VDC on ③, ⑤ terminals when power is applied.

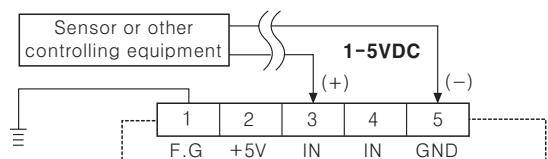

#### 3) ON/OFF External contact control input

It controls 100% if you connect External S/W or relay contact to ②, ③ terminal when it is ON, it controls 0% when it is OFF.

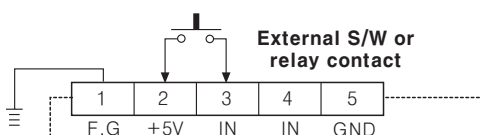

#### 4) External volume control input

After power is applied, connecting the external volume 1k $\Omega$  to ②, ③ and ④ terminals and turning VR control from 0% to 100%.

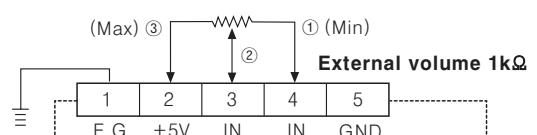

※ Able to control the output with using Out ADJ. according to above control method. When do not use Out ADJ. function please set volume as 100%. (See D-5 page for more explanation of Out ADJ.)

(A) Counter

(B) Timer

(C) Temp. controller

(D) Power controller

(E) Panel meter

(F) Tacho/Speed/Pulse meter

(G) Display unit

(H) Sensor controller

(I) Proximity sensor

(J) Photo electric sensor

(K) Pressure sensor

(L) Rotary encoder

(M) 5-Phase stepping motor & Driver & Controller

# SPC1 Series

## Front panel identification

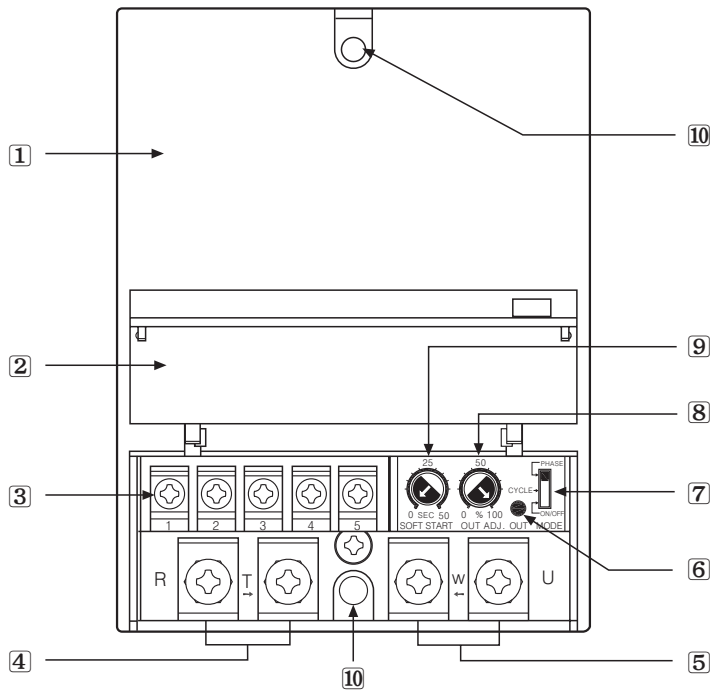

- ① Case
- ② Terminal block cover
- ③ Terminal block for control input
- ④ Terminal block for connecting power
- ⑤ Terminal block for connecting load
- ⑥ The LED display of output
- ⑦ Selection S/W of control mode
- ⑧ The volume of SOFT START
- ⑨ The volume of OUT ADJ.
- ⑩ The hole for fixing on panel  
(Bolt size: M4×50)

## Factory Default setting

Control mode	Phase control mode
Control type	Phase equality division type according to control input
Control cycle	0.5sec
SOFT START setting	0sec
OUT ADJ. setting	100%

## How to change additional function

When you need to change control cycle or characteristic control type of phase control mode from factory specification, use JP1, JP2, JP3 on PCB as below.

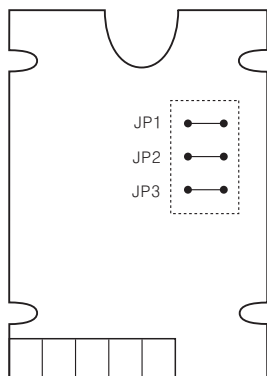

<PCB >

<Select cycle control mode >

JP1	JP2	Period(sec)
SHORT	SHORT	0.5sec
SHORT	OPEN	2.0sec
OPEN	SHORT	10sec
OPEN	OPEN	X(Do not use)

\* SHORT      OPEN

<Select phase control mode >

JP3	Control type
SHORT	Phase equality division type according to control input
OPEN	Power equality division type according to control input

## Operation and function

### Front

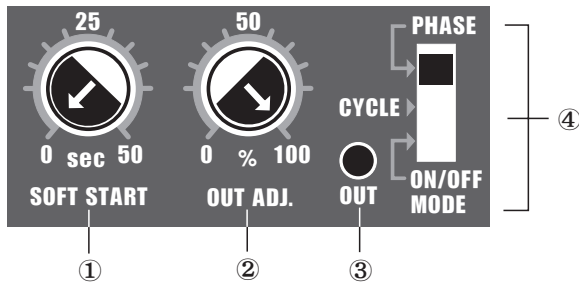

- ① SOFT START time setting volume(0 ~ 50sec.)
- ② Adjusted Output value setting volume(0 ~ 100%)
- ③ Output operation display LED
- ④ Control mode selection S/W
  - PHASE : Phase control mode
  - CYCLE : Cycle control mode
  - ON/OFF : ON/OFF control mode

### Control mode selection

Control mode	Phase control mode	Cycle control mode (Zero Cross)	ON/OFF control mode (Zero Cross)
Mode switch			

※When select cycle control mode, the cycle has been set as 0.5sec, It can be changed to 2.0sec. or 10sec. by jumper function.  
 ※The mode cannot be changed while it is operating. Please be sure to set the proper mode **after turning the power off** then apply the power again.

### 1)Phase control

It is output type to control phase of an alternating signal according to control input signal. Please see D-3 page (How to change additional function) for deviation method.

#### ●Equal division of phase according to control input

This is analog type which divides the control angle equally according to the control input signal. It shows power characteristic as (Fig. 1). There might be areas of under power and over power at points below and above the control input mid point.

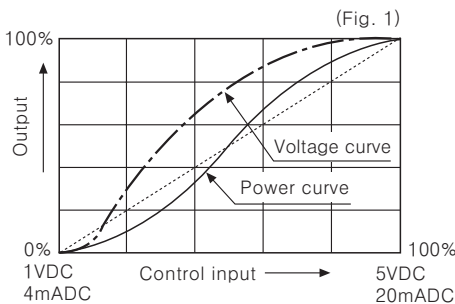

#### ●Equal division of power according to control input

It divides the control angle non-equally according to the control input signal in order to make the power curve linear. Therefore, the output power is directly proportional to the input signal (Fig. 2).

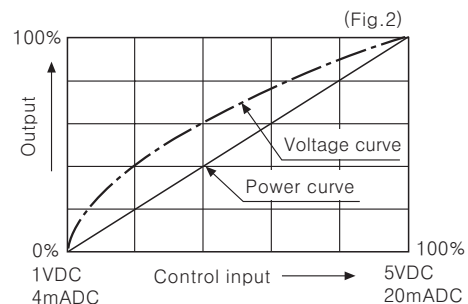

### 2)Cycle control-Zero Cross

It controls the power, which is applied into the load to repeat ON/OFF cycle like below picture with constant proportion according to control input signal. It is easy to control the load and there is no ON/OFF noise because it turns ON and OFF at the zero point of AC.

Usually it is used in a place or electric furnace which is not easily effected by external noise.

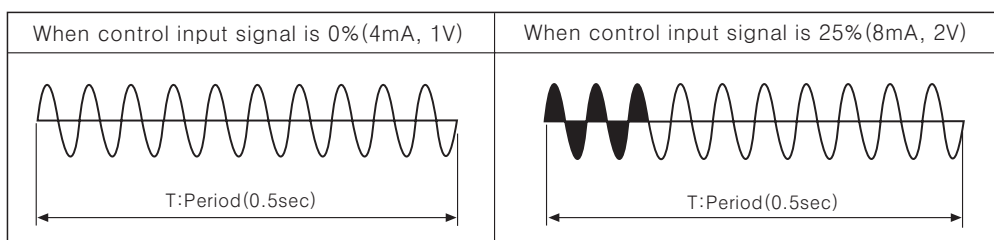

(A) Counter

(B) Timer

(C) Temp. controller

(D) Power controller

(E) Panel meter

(F) Tacho/Speed/Pulse meter

(G) Display unit

(H) Sensor controller

(I) Proximity sensor

(J) Photo electric sensor

(K) Pressure sensor

(L) Rotary encoder

(M) 5-Phase stepping motor & Driver & Controller

# SPC1 Series

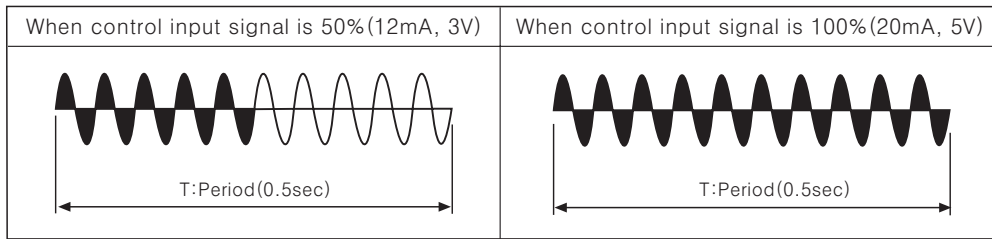

### 3) ON/OFF control-Zero Cross

This function is when control input is ON, output is 100%. When it is OFF, output is 0%. It is the same function as SSR (Solid State Relay).

※ It is not able to use OUT ADJ. and SOFT START function in ON/OFF control mode.

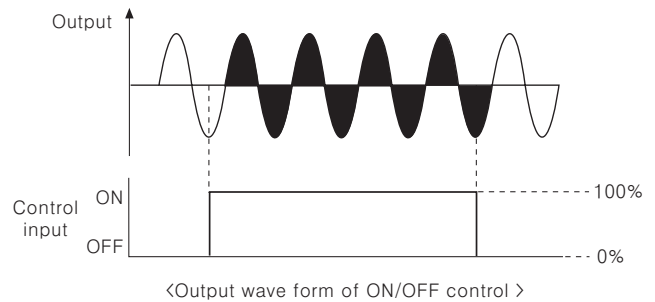

### ◎ OUT ADJ. function (0 to 100%)

This function will be as follows :  
 [Control input (%) × OUT ADJ. (%) = Output] and it controls the power applied into the load.

Ex) Although the control input is 100% (5V or 20mA), if OUT ADJ. is 50%, the output will be 50% which is proportioned with OUT ADJ. When this function is not used, OUT ADJ. should be 100%.

※ This function must not be used in ON/OFF control mode.

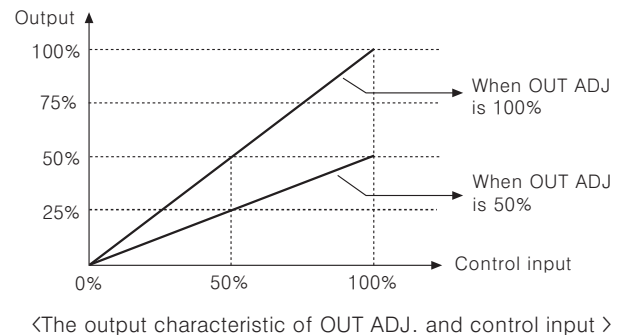

### ◎ SOFT START function (0 to 50sec)

When the power is applied, this function is able to protect the load when it controls load (Molybdenum, White gold, tungsten, infrared Lamp) with inrush current or the width of rising temperature is big (SV is big).

When this function is not used, T should be 0.  
 Note) In this time, if you increase the OUT ADJ. before it reaches T/2, it will slowly increase and then reaches the new output in a total time period equal to T multiplied by the new OUT ADJ. percentage.

※ This function must not be used in ON/OFF control mode.

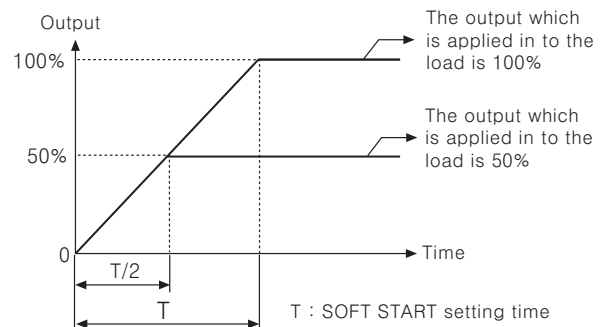

※ T : Time to get the output which is applied in to the load is 100%.

T/2 : Time to get the output which is applied in to the load is 50%.

### ◎ OUT display function

This is LED ramp to display the status of output and will be getting brighter according to output. (0% : Minimum, 100% : Maximum)

## Application

Ex1) When it needs to control accurately by adjusting the power in phase control and cycle control mode.

For example, if need to control 80% output when it is ON, 24% output when it is OFF, please keep below.

: Firstly set OUT ADJ. as 80% and connect external volume and external relay contact S/W as above picture then set external volume as 30%.

●When the External contact signal is ON :  $100\%(\text{External contact input}) \times 80\%(\text{Out ADJ.}) = 80\%$

●When the External contact signal is OFF :  $30\%(\text{Volume input}) \times 80\%(\text{Out ADJ.}) = 24\%$

<Control input terminal connection >

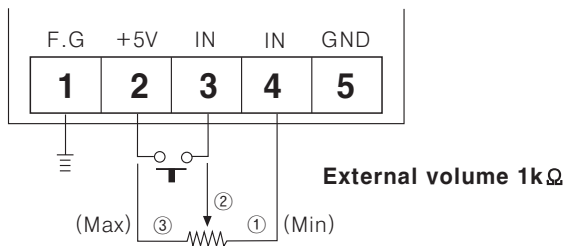

EX2) This is how to control 0 to 100% without external volume in phase control mode and cycle control mode.

: It is possible to control 0 to 100% by turning OUT ADJ. in state of connecting terminal 2 and terminal 3.

<Control input terminal connection >

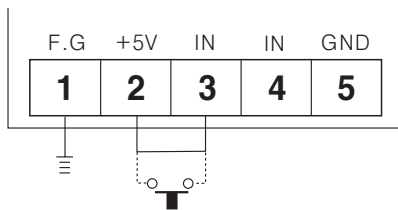

## Proper usage

### Warning

**When using this item, ground F.G terminals to avoid an electric shock.**

**Do not touch the heat plate since it radiates high temperature.**

### Caution

1. When you install it on panel, it should be installed vertically at the place, which is well ventilated.  
If install it horizontally, under 70% of rated current should be applied, and a vent fan needs to be installed on the upper part of panel.
2. Be sure attaching prompt fuse between R phase terminal and power.
3. If over the maximum rated current, it causes product damage.  
(Do not over maximum rated current when using high rush current)
4. Since it is only for resistive load, the inductive load cannot be used.
5. When connecting power and load, please use the cable (When rated current is 35A:Min. 5.5mm<sup>2</sup>, when rated current is 50A : Min. 8.0mm<sup>2</sup>) which is able to send the maximum rated current.
6. Before using this unit, set the proper mode and function.  
Especially, if the setting of Out ADJ. is 0%, it does not operate.
7. The mode cannot be changed while it is operating.  
Please be sure to set the proper mode after cutting the power off and then apply the power.
8. Do not use this unit as following place.
  - ①A place where corrosiveness or inflammable gas is occurred.
  - ②A place where water and oil is occurred.
  - ③A place where there are a lot of dusts.

(A)  
Counter

(B)  
Timer

(C)  
Temp.  
controller

(D)  
Power  
controller

(E)  
Panel  
meter

(F)  
Tacho/  
Speed/  
Pulse  
meter

(G)  
Display  
unit

(H)  
Sensor  
controller

(I)  
Proximity  
sensor

(J)  
Photo  
electric  
sensor

(K)  
Pressure  
sensor

(L)  
Rotary  
encoder

(M)  
5-Phase  
stepping  
motor &  
Driver &  
Controller