

## Distance sensors

## OADM 13 (Laser, current output)

## sample drawing

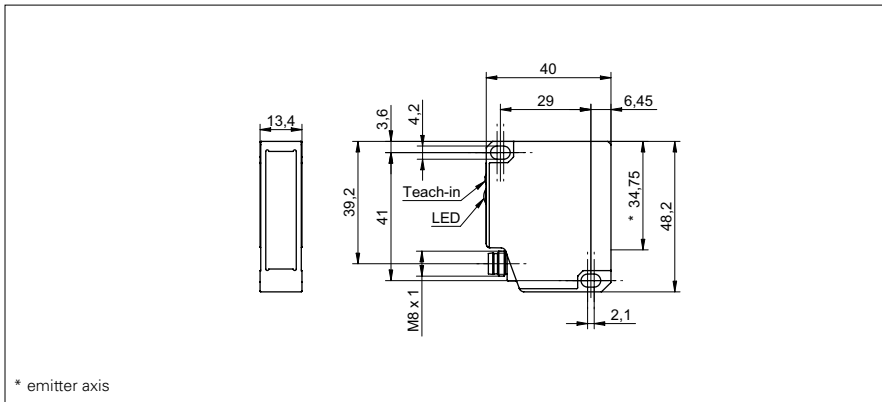

## general data

adjustment	Teach-in: button / external
power on indication	LED green
soiled lens indicator	LED red / LED red blinking
light source	pulsed red laser diode
wave length	650 nm
laser class	2
interference suppression	< 30 ms

## measuring distance Sd = 50 ... 350 mm

Teach-in range min.	> 5 mm
resolution	0,01 ... 0,4 mm
linearity error	± 0,05 ... ± 1,2 mm

## measuring distance Sd = 50 ... 550 mm

Teach-in range min.	> 10 mm
resolution	0,01 ... 1,1 mm
linearity error	± 0,08 ... ± 3,5 mm

## electrical data

voltage supply range +Vs	12 ... 28 VDC
current consumption max.	100 mA
output circuit	analog
output signal	4 ... 20 mA
load resistance	< (+Vs - 6 V) / 0,02 A
short circuit protection	yes
reverse polarity protection	yes, Vs to GND

## measuring distance Sd = 50 ... 350 mm

response time / release time	< 0,9 ms
------------------------------	----------

## measuring distance Sd = 50 ... 550 mm

response time / release time	< 1,5 ms
------------------------------	----------

## sample picture



## Distance sensors

## OADM 13 (Laser, current output)

**mechanical data**

width / diameter	13,4 mm
height / length	48,2 mm
depth	40 mm
type	rectangular
housing material	aluminum
front (optics)	glass
connection types	connector M8 4 pin

**ambient conditions**

operating temperature	0 ... +50 °C
protection class	IP 67

order reference	measuring distance Sd	response time / release time	beam type	beam width	beam height	beam diameter
<b>OADM 1316475/S35A</b>	50 ... 350 mm	< 0,9 ms	point	-	-	1 mm
<b>OADM 1316480/S35A</b>	50 ... 550 mm	< 1,5 ms	point	-	-	1 mm
<b>OADM 1316575/S35A</b>	50 ... 350 mm	< 0,9 ms	line	2 mm	4 ... 9 mm	-
<b>OADM 1316580/S35A</b>	50 ... 550 mm	< 1,5 ms	line	2 mm	4 ... 13 mm	-