

Optical Bracket Photoelectric Sensors



TEACH-IN OPTICAL BRACKETS 12 ÷ 30 V DC PROGRAMMABLE OUTPUT

- 3 mm gap X 60 mm deep for flexible installation
- Teach-in standard or sensitive calibration automatically sets sensitivity values
- Fast response time: 10 K Hz switching frequency
- Remote Teach-in allows fast target changeover by the host
- Applications include: Translucent material - Double detection - Edge detection

FF Series



Identification code

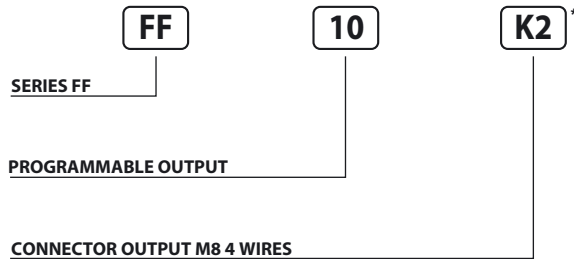

* Available only with K2 connector output

CLEF	3 mm
EMISSION	Infrared (875 nm)
NOMINAL VOLTAGE	12 ÷ 30V DC (-15 / +10%)
RESIDUAL RIPPLE	≤ 10%
OUTPUT	Programmable NPN or PNP
MAX OUTPUT CURRENT	100 mA
ABSORPTION AT 30 V DC	≤ 40 mA
VOLTAGE DROP (Sensor ON)	≤ 2 V (I = 100 mA)
RED LED	Memorization - Standard teach-in
GREEN LED	Object presence/absence - Thin teach-in
SWITCHING FREQUENCY	10.000 Hz
RESPONSE TIME	100 mS
START UP DELAY	≤ 100 mS
SHORT CIRCUIT PROTECTION	Present (self-resetting)
ELECTRIC PROTECTIONS	Against polarity reversal
TEMPERATURE LIMITS	-10 ÷ +60°C
LIGHT IMMUNITY	3.000 Lux
PROTECTION DEGREE	IP 65
CABLE SECTION	M8 4 wires connector
HOUSING MATERIAL	Anodised aluminium
WEIGHT (Approximate)	85 g

Note: for a proper use see norms at pages 14, 15, 16, 17 and 18.

Wiring diagrams

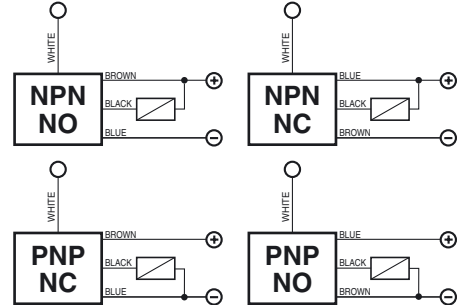

Note: If the white wire is not used for external teach-in, connect it to ground.

Wiring diagrams with M8 connector (K)

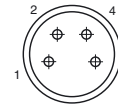

View of quadrupole male connector.

CONTACTS CONFIGURATION

Output	Contacts numbers			
	1	2	3	4
NPN/PNP NO	-	White	+	Out
NPN/PNP NC	+	White	-	Out

Note: Use only the female connector type K2FDV. If the contact n. 3 (white wire) is not used for external teach-in, connect it to ground.

Dimensions (mm)

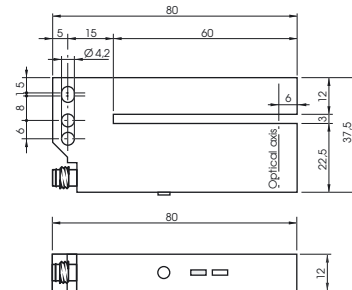

Adjustment

STANDARD TEACH-IN (TO DETECT STANDARD TAGS)

PHOTOELECTRIC SENSOR POSITION

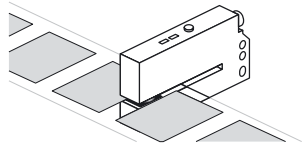

WARNING: The photoelectric sensor teach-in must be executed by placing the photoelectric sensor on the tag traslucid support (not directly on the tag which has to be detected).

- 1) Set the optical bracket on the tag support.
- 2) Push once the button: the red led light will be blinking through 2 seconds.
- 3) Push again the adjustment button and keep it pushed till the definitive swifching of the red led (memorization achieved).

Warning: if during the adjustment the red led and the green led are blinking at the same moment, it means that a short-circuit occurs at the output or that the tag support is too opaque.

STATUS LED

RED LED BLINKING THROUGH 2 SECONDS



RED LED ON



RED AND GREEN LEDS BLINKING



THIN TEACH-IN (TO DETECT TRASLUCIDE TAGS)

PHOTOELECTRIC SENSOR POSITION

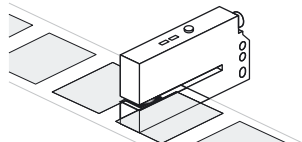

WARNING: The photoelectric sensor teach-in must be executed by placing the photoelectric sensor on the tag traslucid support (not directly on the tag which has to be detected).

- 1) Set the optical bracket on the tag support.
- 2) Push twice the button: the green led light will be blinking through 2 seconds.
- 3) Push again the adjustment button and keep it pushed till the definitive swifching of the red led (memorization achieved).

Warning: if during the adjustment the red led and the green led are blinking at the same moment, it means that a short-circuit occurs at the output or that the tag support is too opaque.

LED DI STATO

GREEN LED BLINKING THROUGH 2 SECONDS



RED LED ON



RED AND GREEN LEDS BLINKING



The same teach-in mode achieved by pushing the button can be also obtained by connecting the white wire to the positive (external teach-in), following the same steps envisaged for teach-in through the button. For a correct installation see norms at pages 7, 8, 9 and 10