

## BAT 1 956 S - BAT 2 956 S



- Sensing distance on reflector 50x50 mm :  
BAT 1 : 0-80 cm - Reflector at 80 cm max.  
BAT 2 : 0-140 cm - Reflector between 40 cm and 140 cm
- Supply : 10 / 30 VDC
- Output : PNP / NPN
- Teach-in
- Time-delay of output signal



### Description :

- Simple and quick set-up for self-teach
- Coaxial transmitter-receiver
- Immunity to reflections interferences
- Adjustable timer
- Alignment indicator
- Dirty optics indicator
- Keyboard lock
- Remote input for self-teach
- Direct or inverse output
- Output : PNP / NPN
- M8 connector
- Polycarbonate strong housing

### Applications :

- Through-beam on a conveyor : glass
- Detection of transparent parts (glass, PET,...).
- Bottle detection on blow moulding machinery (PET, glass, ...).

### Dimensions

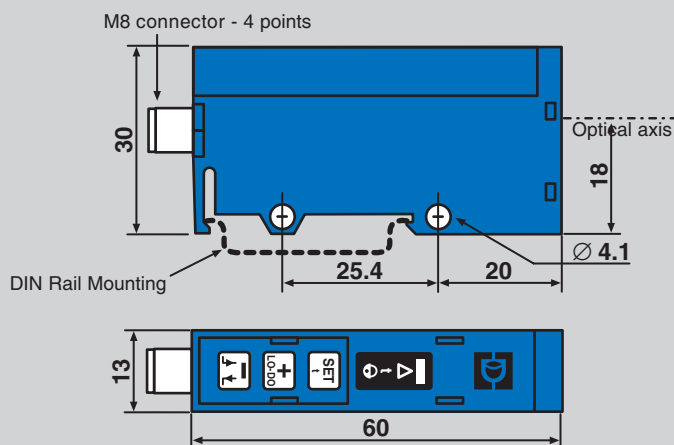

### Wiring Connections

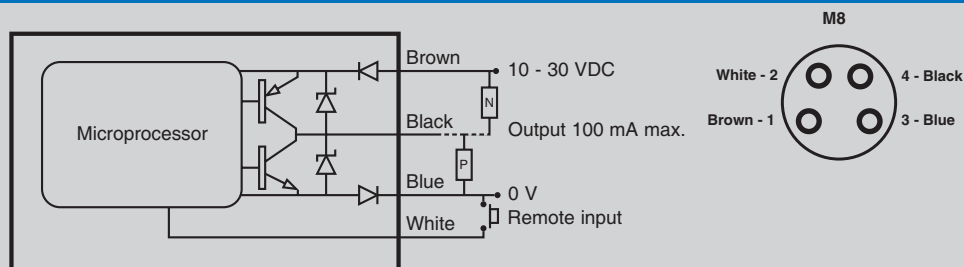

### Visualisation and Adjustment

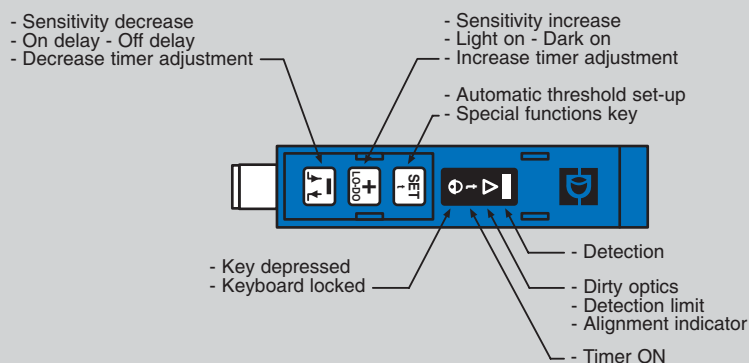

## Technical Information

<b>Supply</b>	voltage	10 / 30 VDC ripple < 10% within specified limits
	consumption	< 45 mA
<b>Response time</b>	t <sub>on</sub> or t <sub>off</sub>	< 500 µs
	switching frequency	< 1 KHz
<b>Output</b>	max. nominal intensity	100 mA
	residual voltage at 100 mA	< 2 V
	residual voltage at 10 mA	< 1 V
<b>Emission</b>	LED	red
	modulation frequency	8 KHz
<b>Timer</b>	range	0 to 5 s with 11 increments
	increment duration	first increment : 40 ms, following increments : 500 ms
<b>Temperature</b>	operating	0 to 50 °C
	storage	-20 to 80 °C
<b>External light immunity</b>	incandescent light	10 000 lux
	sunlight	20 000 lux
<b>Protections</b>	supply	inverse polarity protection
	output	permanent short-circuit or over-load protection
	degree of protection	IP 67 (connector on place)
<b>Remote input</b>	on	voltage < 1.4 V
	off	voltage > 3 V

## To Place Order

<b>Product</b>	Sensor for transparent products
<b>Reference</b>	BAT 1 CO 956 S
	BAT 2 CO 956 S
Cable for M8 connector To order together with the sensor	CM 82 - cable 2m CM 82 C - cable 2m with right angle connector CM 85 - cable 5m CM 85 C - cable 5m with right angle connector

### TYPES OF APPLICATIONS

#### Example 1

Detection of a plastic film.

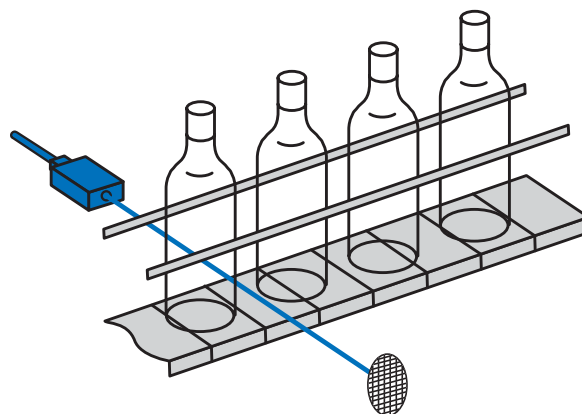
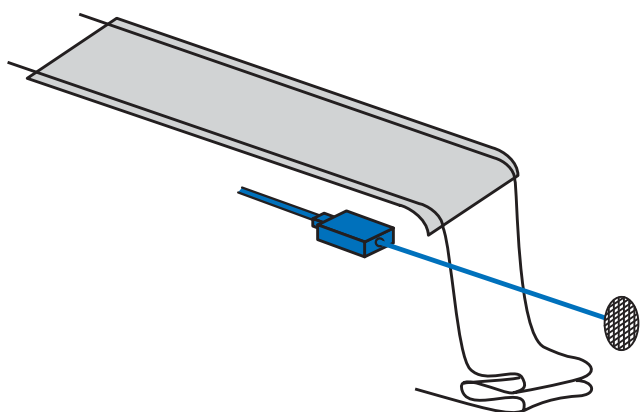

#### Example 2

Detection of transparent bottles (glass, PET,...).