

BAT 0618 S - BLT 0618 S



- Sensing distance on supply reflector 50x50 mm (1111HP):
BLT : 0-80 cm
BAT : 0-140 cm
- Supply : 10 / 30 VDC
- Output : PNP / NPN
- Teach-in

Description :

- Simple and quick set-up for self-teach
- Anti Dust feature (Auto adjustment)
- Coaxial transmitter / receiver
- No blind zone
- Immunity to reflections interferences
- NO/NC by teach
- Output : PNP / NPN
- M8 connector or cable
- Plastic or Stainless Steel M18 enclosure

Applications :

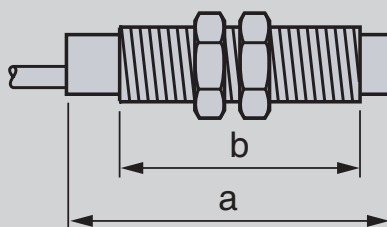
- Through-beam on a conveyor : glass
- Detection of transparent parts (glass, PET,...).
- Bottle detection on blow moulding machinery (PET, glass, ...).

Dimensions

Ø 18, line of sight along case axis

Ø 10 Ø 18, line of sight 90° to case axis

Pre-cabled (mm)		Plug-in connector (mm)	
a	b	a	b
64	44	78	44
78	44	92	44

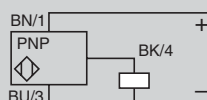
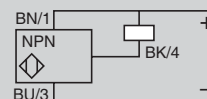
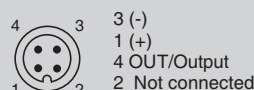
Wiring Connections
PNP

NPN

M12 connector

Pre-cabled

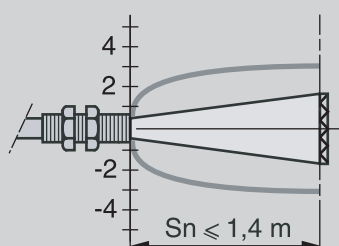
(-) BU (Blue)
(+) BN (Brown)
OUT/Output BK (Black)

Detection curves with reflector 1111HP
With reflector 1111HP

Line of sight along case axis



Line of sight 90° to case axis

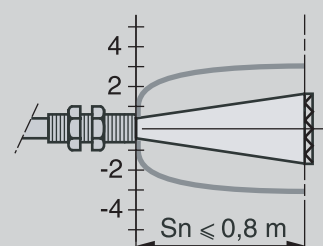

Technical Information

Supply	voltage	10 / 30 VDC ripple < 10% within specified limits
	consumption	45 mA
Response time	Response and recovery	< 500 µs
	First-up	< 200 ms
	switching frequency	< 1 KHz
Output	max. nominal intensity	100 mA
	Voltage drop, closed state	< 2 V
Emission	Output state	Yellow LED
	Supply on	GreenLED
	Stability	Red LED
Temperature	operating	0 to 50 °C
	storage	-40 to 70 °C
Protections	supply	inverse polarity protection
	output	permanent short-circuit or over-load protection
	degree of protection	IP 65, IP 67, double insulation

To Place Order

Product	M18 Sensor for transparent products	
Line of sight	Straight 90° angle	BAT BLT
Output	PNP NPN	B●T ●0618 SP B●T ●0618 SN
Material Case	PBT Stainless steel (grade 304Cu)	B●T P B●T I
Retro-reflex polarised sensor (relay)	Output with cable 2 m	B●T ●0618 S● 2m
	Output with cable 5 m	B●T ●0618 S● 5m
	Output with M12 connector	B●T ●0618 S● M12
Cable for M12 connector	length 2 m	- straight CM 122
	length 5 m	- straight CM 125
		- 90° angle CM 125 C

TYPES OF APPLICATIONS

Example 1

Detection of a plastic film.

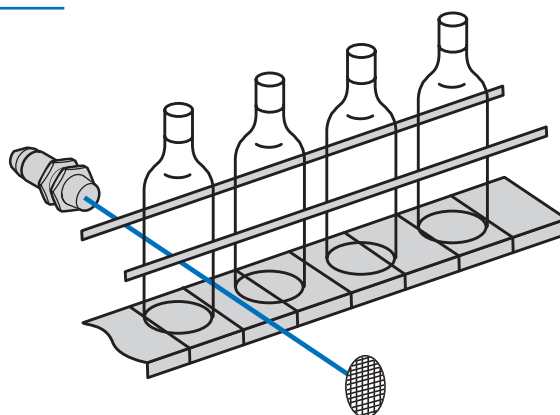
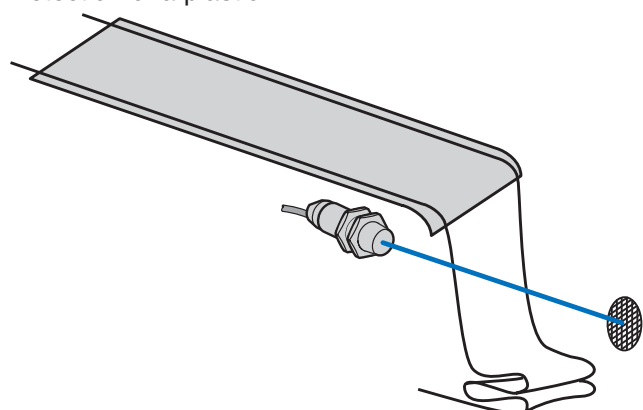

Example 2

Detection of transparent bottles (glass, PET,...).