

3 GUIDE CYLINDER

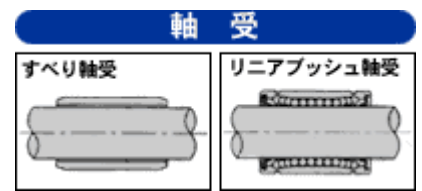

Three guides evenly placed by the high-precision baffle mechanism and the elevator for the cylinder as the eccentric load lost my direction. Length shorter than conventional cylinders to the miniaturization of a space-saving effort.



Bush sliding bearing linear was bearing two types of bearing applications to match the available real estate.



LIFT TYPE

As for elevating the cylinder-mounting surface to work extensively taking three of rod guide to lightweight aluminum body evenly placed in the space could improve with the eccentric load of lost my direction.

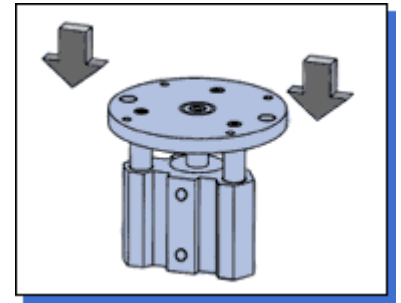
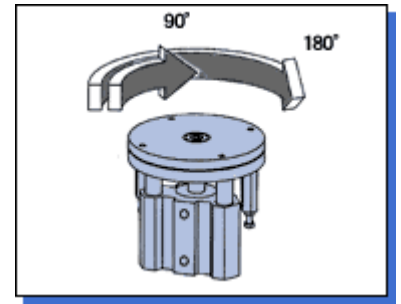

TABLE TYPE

Leave the lift cylinder features high precision cross bearing Have turntable added. Turntable stop the angle of 90 ° to 180 ° of the two offers, the line to improve productivity.



APPLICATION EXAMPLE

位置決め

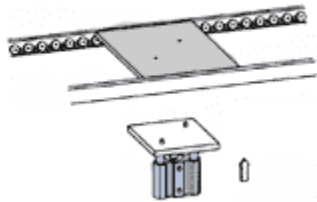

One Position flowing palette of high-precision positioning.

直角転換

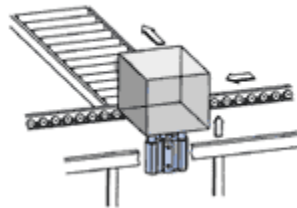

Three guides employed by the more stable orthogonal transformation and transfer can work.

手動作業台

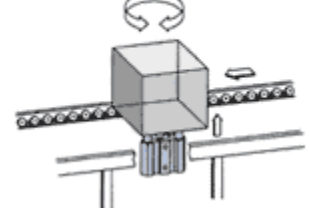

The table type is a flow line from lifted after manually rotating platform.